

## Centralized or Decentralized?

Which Architecture Type Delivers the Best Technical and Commercial Advantages?

**KOLLMORGEN**

*Because Motion Matters™*

Decentralizing servo technology can bring machine and plant construction savings during installation. Two additional advantages include reduced cabinet heat loads and more straight forward drive architecture. The question arises however, which technology is better, an integrated motor/drive solution or a detached motor and drive?

---

*So often in life the answer to a question is neither A or B, but instead C. This is true for the discussion of decentralized versus centralized servo technology in determining the best system. What architecture is best from a commercial and technical standpoint for a particular application? Instead of A or B, the answer C comes about through mixed architectures, a coexistence of both types. In this case the two approaches can be easily combined when the drives have a large number of common features. As such, standardization of these platforms is the best approach.*

---

### The Centralized Architecture

In contrast to horizontal conveying where decentralized servo drives are a common sight, centrally located servo drives are still dominate in the market for highly dynamic and precise motion control. Servo drives along with other control components, sometimes with a full blown IPC, reside together in a control cabinet protected from the outside world. Connection to the [motors](#) is in a star shaped structure, each having control and power cables. Because heat loss is centrally generated, effective air conditioning is needed in the cabinet.

### The Decentralized Alternative

Decentralized servo technology follows the basic principal of shifting the individual motor control from the central control cabinet to be closely located to the process. This architecture makes necessary a robust design providing a high degree of environmental protection. The advantage lies particularly in terms of

motor cabling. Two other advantages are improved EMC-behavior and the widespread distribution of heat loss, reducing the cost or need for a centralized cabinet climate control system.



*Kollmorgen specifically designed the distributed servo drives for AKD-N range as distributed devices, so that there are no deductions in power density.*

### Trends in Machine Building Industry

Especially with packaging machinery and machines for the [food and beverage industry](#), the trend is away from meter long cabinet walls but instead installing small, highly self-protected units within the machine frame. The progressive trend is toward modularization of production facilities making necessary the distribution or combination of functions. This statement is reinforced by the fact that production equipment consist of a main process and ancillary tasks. The latter are a variety of compatible modules – for example conveyor systems, sorters and handling units. This provides a path for easy expansion of the machine. Against this backdrop, practical experience shows that a decentralized structure is advantageous,

## Centralized or Decentralized? Which Architecture Type Delivers the Best Technical and Commercial Advantages?

especially with spatially distributed single axes. In contrast, machine modules for synchronized axis physically close together and centrally located drives in a cabinet are generally considered the preferred structure.

### Monetary Savings in Installation and Mounting

The savings potential of decentralized technology can be clearly shown based on a real metal forming machine having eight axes. The first axis of which is located 5 meters away from the control cabinet with each additional axis located 3 meters further. A centralized control system would be characterized by a central control cabinet housing the drives with each motor having separate shielded power and feedback cables adding up to 248 meters of cable.

Instead, a combination of a single Kollmorgen AKD-C power supply module and 8 [decentralized AKD-N servo controllers](#) would reduce the cable requirement from 248 meters to 34 meters. The calculation: A single 5 meter hybrid cable supplying power and field bus for axis control is connected between the power supply module and the first decentralized controller. A single hybrid cable 3 meters long connects each additional drive for a total of 21 meters. Because we assume that each motor is located 1 meter away from each decentralized AKD-N drive Kollmorgen provides a one-cable motor connection technology, only 8 additional meters of cable is required. Overall, the decentralized system reduced the cable requirements from 248 to 34 meters, a savings of 86 percent. These figures represent an idea of the overall monetary gains for the OEM including cable costs and reduction in assembly effort. When the axes require additional I/O the reduction in cabling is even more obvious. Instead of 372 meters, only 42 meters is needed, a corresponding saving of 89 percent.

Another benefit of the relocation of drives is the reduction of power dissipated in the control cabinet. This effectively reduces the requirements for air conditioning thus providing direct saving for both the OEM and end user. As such, the control cabinet air conditioner can be reduced in size or completely eliminated, reducing costs for hardware and subsequent operation – ultimately increasing energy efficiency.

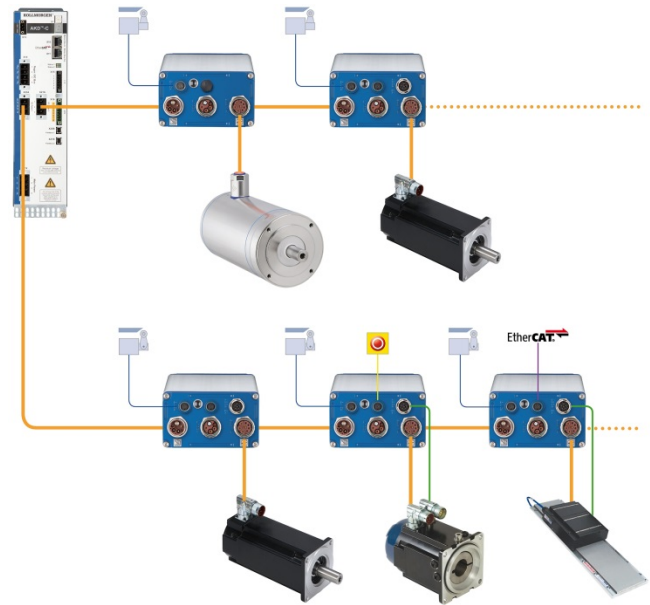

*This layout is distributed servo drive architecture with AKD-N servo drives, different motor types, and single-cable connection technology.*

### Technical Advantages by Decreasing Complexity

The AKD -N series Kollmorgen drives provide IP67 protection and connection via an eleven millimeter diameter hybrid cable to the central supply module in the control cabinet. This single cable provides power and communications without the need for any additional cabling. Each AKD-C supply module can support two strings of AKD-N drives up to 4 kW each and up to 8 AKD-N drives per string. Safe Torque Off shutdown performed via the hybrid cable comes as standard, and can be implemented for each drive individually or as group. Also, only one cable is necessary between the distributed servo controller and its connected motor thanks to a new single-cable



*The torque motors in the KBM series reveal their full strength when it is really tight in machines. These advantages work very well in connection with the decentralized AKD-N servo drives.*

technology. Two cables are no longer required to provide motor power and feedback. In material handling applications where precise motion is demanded, separate cable trays or tow chains are often required for motor and feedback cables. This requirement is now reduced because there is much less cabling.

## Centralized or Decentralized? Which Architecture Type Delivers the Best Technical and Commercial Advantages?

### Winning with Increased Design Freedom

Sample calculations show that the decentralized servo technology saves space in combination with the single-cable connection technology between motor and controller. This benefit results in smaller cable trays, lighter drag chains, and more compactness giving more design freedom in the development of new machines. This freedom resulted primarily from the fact that the distributed technology extends modularization capabilities in comparison to the inflexible, central control design. The bottom line is that this allows new OEM plants to create new machines from already developed modules making the engineering more efficient.

### Distributed Drive Technology as a Hybrid

A second way to decentralize is with the use of a hybrid integrated solution. These are combined motor and [servo controller](#) units without the need for external wiring. This “piggyback” solution has the disadvantage of drive derating with increased ambient temperature. The higher the ambient the more performance reduction occurs in order for the drive to self-protect from overheating. This relationship ensures in practice that the motors must be larger than otherwise necessary to give the required performance within acceptable temperature limits for the electronics. Typical servo tasks such as rapid acceleration and deceleration during positioning can be especially difficult in the design of hybrid solutions due to the problem of effectively dissipating heat. However, separating the motor and drive at this point prevents the inherent design-related derating. This solution provides the basis for smaller motors in combination with better energy efficiency. In addition, integrated combinations are usually focused on a single motor type, limiting flexibility in the machine design. In contrast, any Kollmorgen brushless motor type can be connected to the decentralized AKD-N servo drive. These motors include conventional or direct drive rotary and linear direct drive types, providing true design freedom and optimum performance,

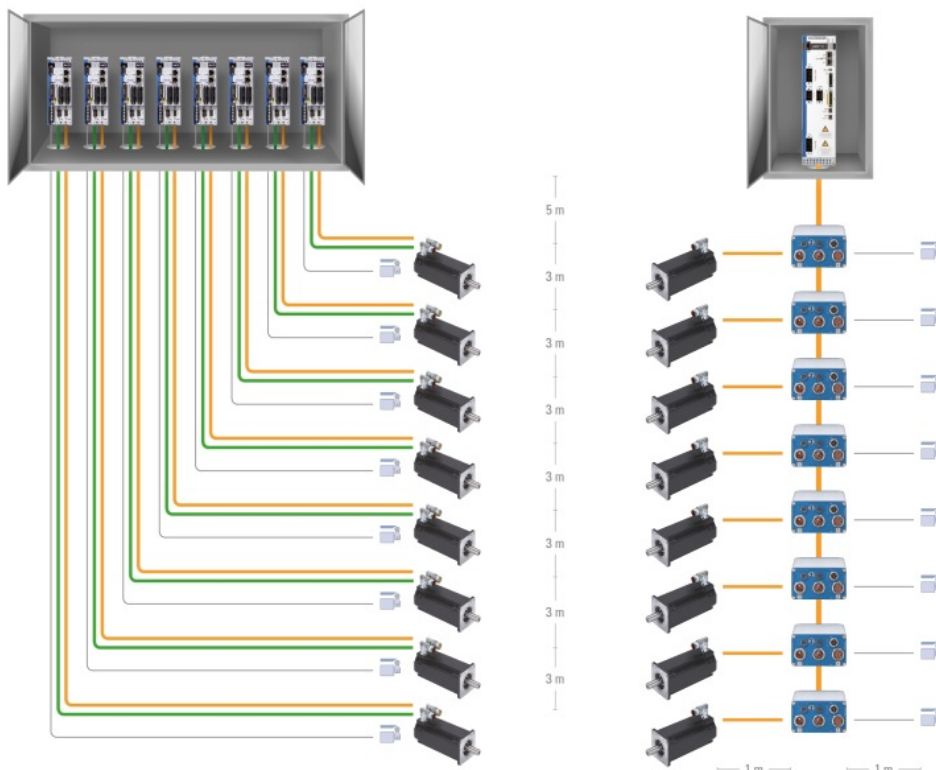

*It's true that at first glance they're just cables, but these push up the installation costs and take up space inside machines. The comparison between central and distributed layout speaks for itself.*

## Centralized or Decentralized? Which Architecture Type Delivers the Best Technical and Commercial Advantages?

### An Integration Example

In conclusion, to clarify these relationships an example of servo drive technology for a food processing machine will be shown. The process begins with the cutting of sausage and cheese by a slicer. The product is conveyed onto a belt. The process is not just a simple matter of conveying a sausage stack from point A to B but to transport it as well defined shingles. The need for highly dynamic single axis positioning system is clear. The question now arises how to integrate the required sophisticated motion control functions while maintaining centralized machine control. The slicer provides a good example because it represents a specific decentralized axis because its high power requirement cannot be met with a decentralized drive. The primary objective from the manufacturing perspective is to harmonize highly diverse functional requirements for a wide combination of centralized and decentralized solutions. The Kollmorgen AKD-N drive deliberately focuses on the use of a centralized AKD platform. It provides appropriate technology to allow the optimum selection of a motion solution for the performance task required, offered through the wide variety of compatible actuators.



*It's true that at first glance they're just cables, but these push up the installation costs and take up space inside machines. The comparison between central and distributed layout speaks for itself.*



**Author:** Dr. Arne Linder  
Project Manager  
Kollmorgen, Ratingen

### ABOUT KOLLMORGEN

Since its founding in 1916, Kollmorgen's innovative solutions have brought big ideas to life, kept the world safer, and improved peoples' lives. Today, its world-class knowledge of motion systems and components, industry-leading quality, and deep expertise in linking and integrating standard and custom products continually delivers breakthrough solutions that are unmatched in performance, reliability, and ease-of-use. This gives machine builders around the world an irrefutable marketplace advantage and provides their customers with ultimate peace-of-mind.

For more information visit [www.kollmorgen.com](http://www.kollmorgen.com), email [support@kollmorgen.com](mailto:support@kollmorgen.com), or call 540-633-3545.